

18 August 1996

# CONSTRUCTION AND ASSEMBLY MANUAL

(p/n 564-8121)



**RST ENGINEERING**

MAIL: 13249 Grass Valley Ave  
SHIP: 13993 Downwind Court  
Grass Valley CA 95945  
(916) 272-2203 (voice & fax)  
E-mail: sales@rst-engr.com  
Web Page <http://www.rst-engr.com>

## **RST-564 Audio Selector Panel Printer Prototype3 (cardboard cutout) Version**

Welcome to the "cardboard cutout" version of the RST-564 Audio Selector Panel. This model is intended to allow you to "install" the audio panel into your aircraft for form and fit before actually purchasing the full kit. We are pleased to give you this model with our compliments and hope that you find a good use for it. If you want another copy, it is available on our website at [www.rst-engr.com](http://www.rst-engr.com) in a .zip format with .gif graphics.

### INSTRUCTIONS:

1. The completed model should resemble the conceptual view shown in drawing 564-0600.
2. Print or copy the Cutout Model pages (drawings 564-0610, 0611, 0612, & 0613) on a sheet of moderately heavy paper or card stock. Check the dimensions given on each sheet to be sure that your printer or copier has not enlarged or reduced the 1:1 drawing size of the original drawing.
3. Cut out the five main components of the marker receiver: Main Chassis, Cover, Mounting Tray, and Faceplates. (Note -- in the "real" kit, the faceplate is BLACK with WHITE lettering.)
4. Main Chassis: Fold the side chassis lips ("N" and "P") at the line DOWN (away from the printing) at a right angle. Fold front and rear lips ("H" and "K") down at a right angle. Fold front and rear surfaces ("I" and "J") down. You should have a structure that resembles the main chassis as shown on the 3-D view. (Note -- all printing will be on the OUTside of the chassis.)
5. Cover: Fold the two sides ("L" and "M") down at the lines. Test the cover for fit over the chassis and make any minor bending corrections that may be necessary for fit. Note that the cover holes will only line up one way on the chassis.
6. Mounting Tray: Fold the two sides ("E" and "G") down at the line. Fold the hold-down tab ("F") down at the line
7. Faceplate: The faceplate in the "real" unit has small colored lenses at IM (red), MM (yellow) and OM (green). There are also 11 toggle switches protruding 0.3" out the front of the faceplate. Simulate these parts any clever way you wish (colored candy at the lights and a cutoff toothpick for the switch handles) and then glue the faceplate to the main chassis. The faceplate will be held to the chassis by the switch threads in the "real" version.
8. To make the simulation complete, there are two 12 pin nylon shell connectors and one 15 pin nylon shell connector coming out the three holes on surface "J" of the main chassis. These connectors are about the size of two sugar cubes side by side. You can simulate them with balsa wood or other lightweight material. When you are happy with the way it looks, glue or tape the unit together.

Please note that you will have to fly this unit and note conformance to the FARs before using it under actual instrument conditions!!!

Enjoy,

Jim Weir  
VP Engineering

Gail Allinson  
Information Systems Manager

Chassis Cover  
Drawing # 564-2300

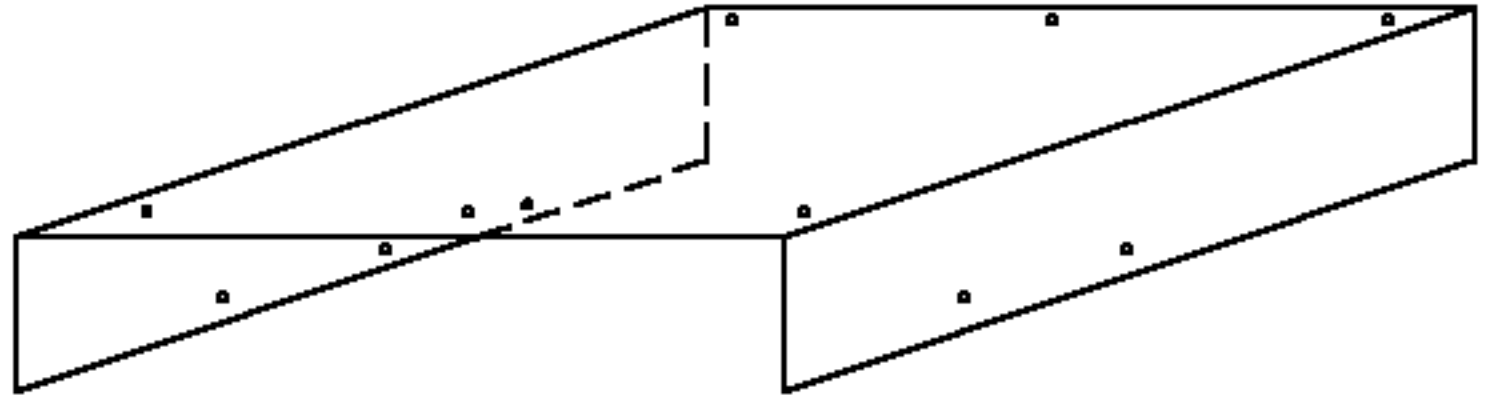

Main Chassis  
Drawing # 564-2200

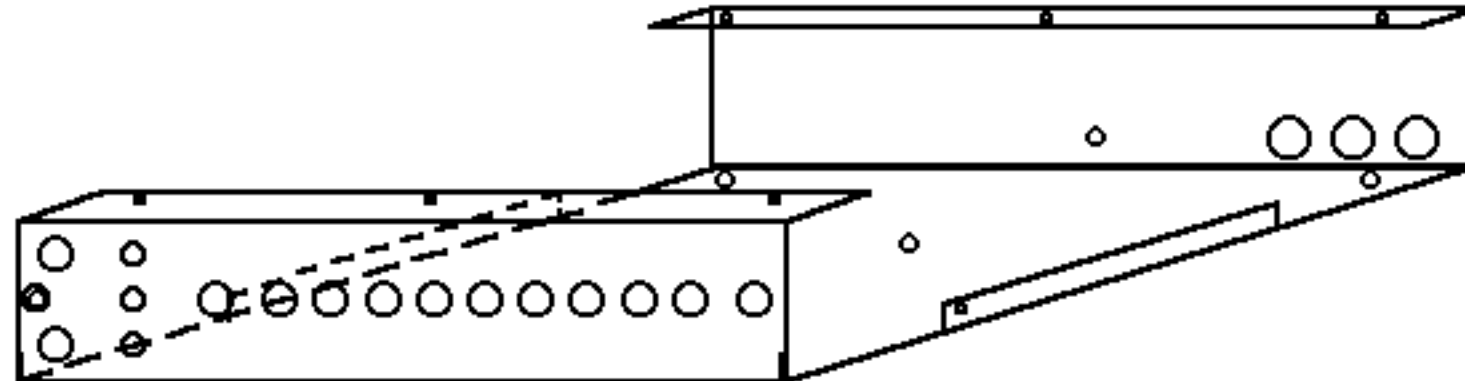

Faceplate  
Drawing # 564-2100

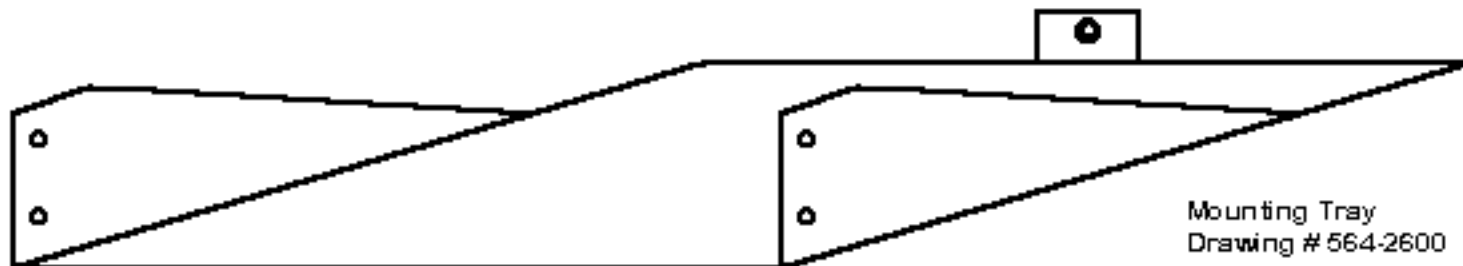

Mounting Tray  
Drawing # 564-2600

**RST-564 Audio Selector Panel  
CONCEPTUAL CHASSIS ASSEMBLY**

Scale: NTS

Approved by:

Drawn by: OWJ

Date: 15 Dec 96

Jim Weir

Rev: A

**RST Engineering**

13249 Grass Valley Ave Grass Valley CA 95945  
916/272-2203 (voice & fax) rst-engr@oro.net

Drawing #

564-0600

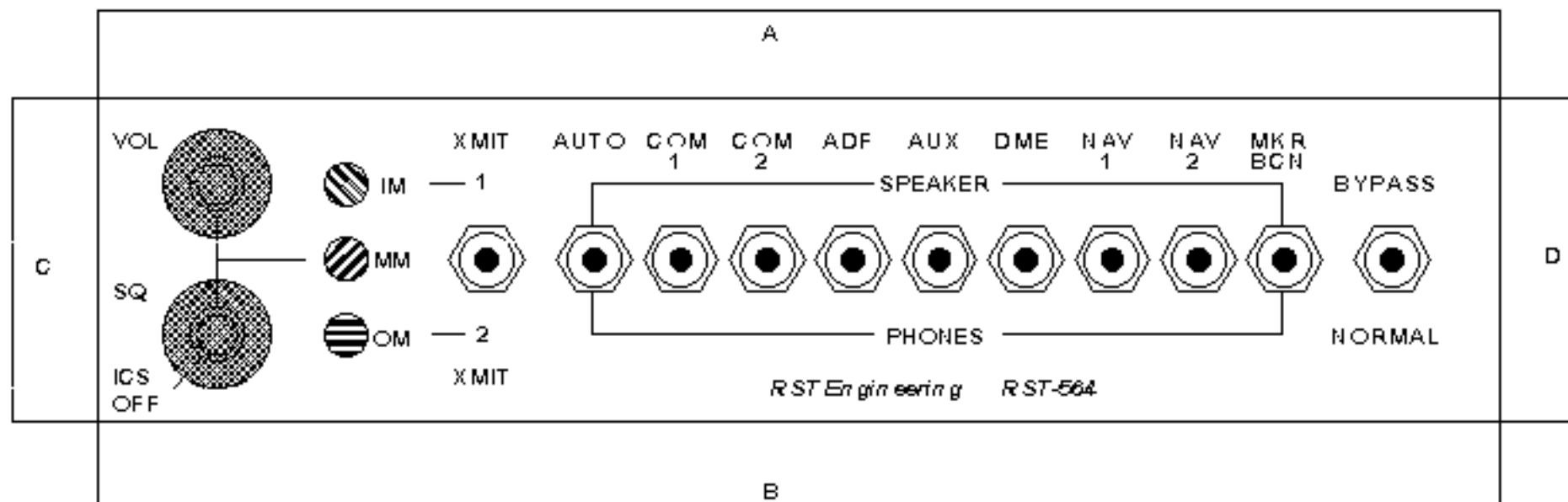

Cutout size: 2.3" x 7.3"

**FACEPLATE**  
Printer Prototype

Scale: 1:1

Drawn by: OWJ

Approved by:

**RST Engineering**

Drawing #

Date: 17 Dec 96

Rev: A

Jim Weir

13249 Grass Valley Ave Grass Valley CA 95945  
916/272-2203 (voice & fax) rst-engr@oro.net

564-0610

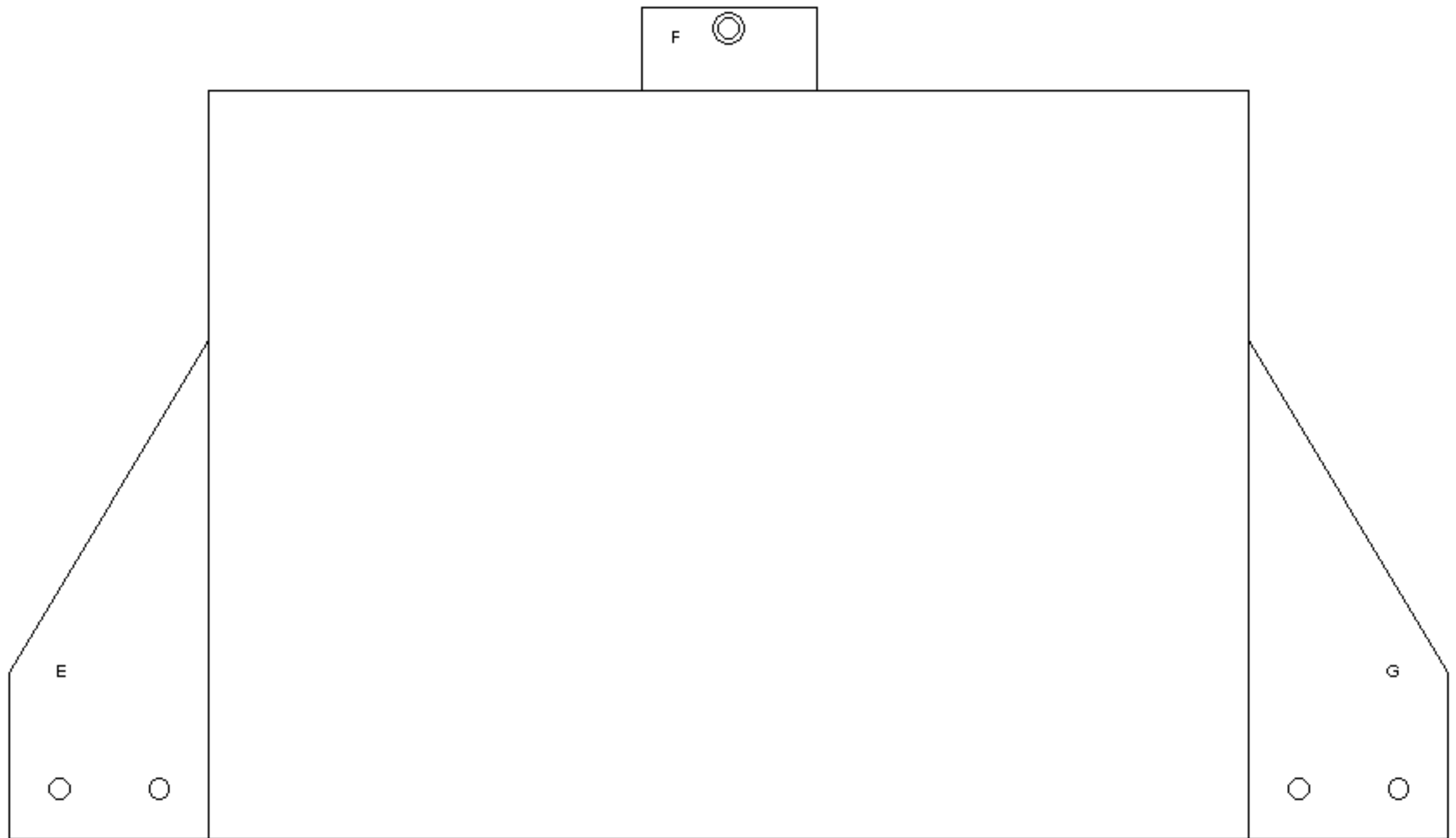

Cutout size: 5.0" x 8.65"

**MOUNTING TRAY**  
Printer Prototype

Scale: 1:1

Drawn by: OWJ

Approved by:

**RST Engineering**

Drawing #

Date: 17 Dec 96

Rev: A

Jim Weir

13249 Grass Valley Ave Grass Valley CA 95945  
916/272-2203 (voice & fax) rst-engr@oro.net

564-0611

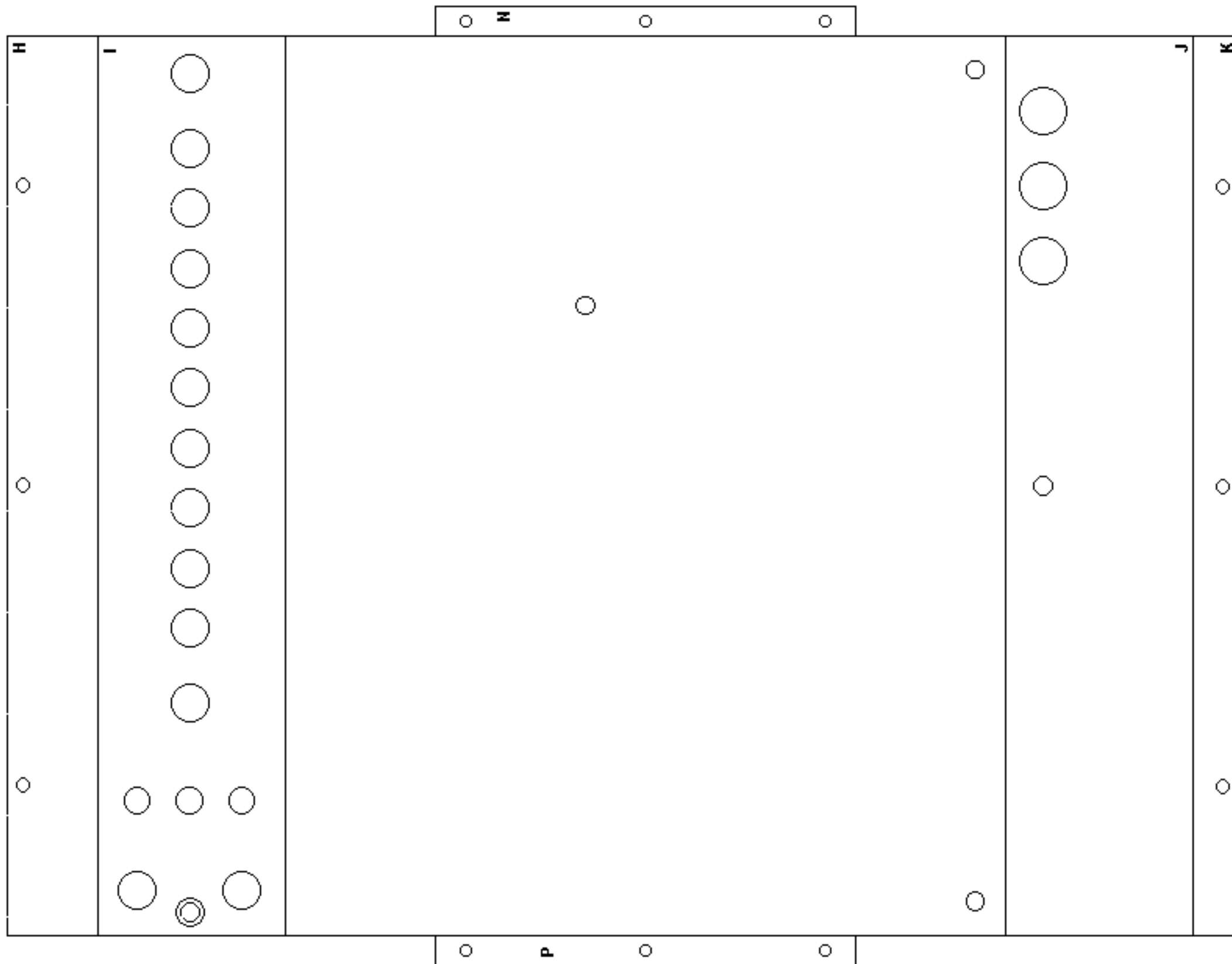

Cutout size: 6.4" x 8.2"

**MAIN CHASSIS**  
Printer Prototype

Scale: 1:1

Drawn by: OWJ

Approved by:

**RST Engineering**

Drawing #

Date: 17 Dec 96

Rev: A

Jim Weir

13249 Grass Valley Ave Grass Valley CA 95945  
916/272-2203 (voice & fax) rst-engr@oro.net

564-0612

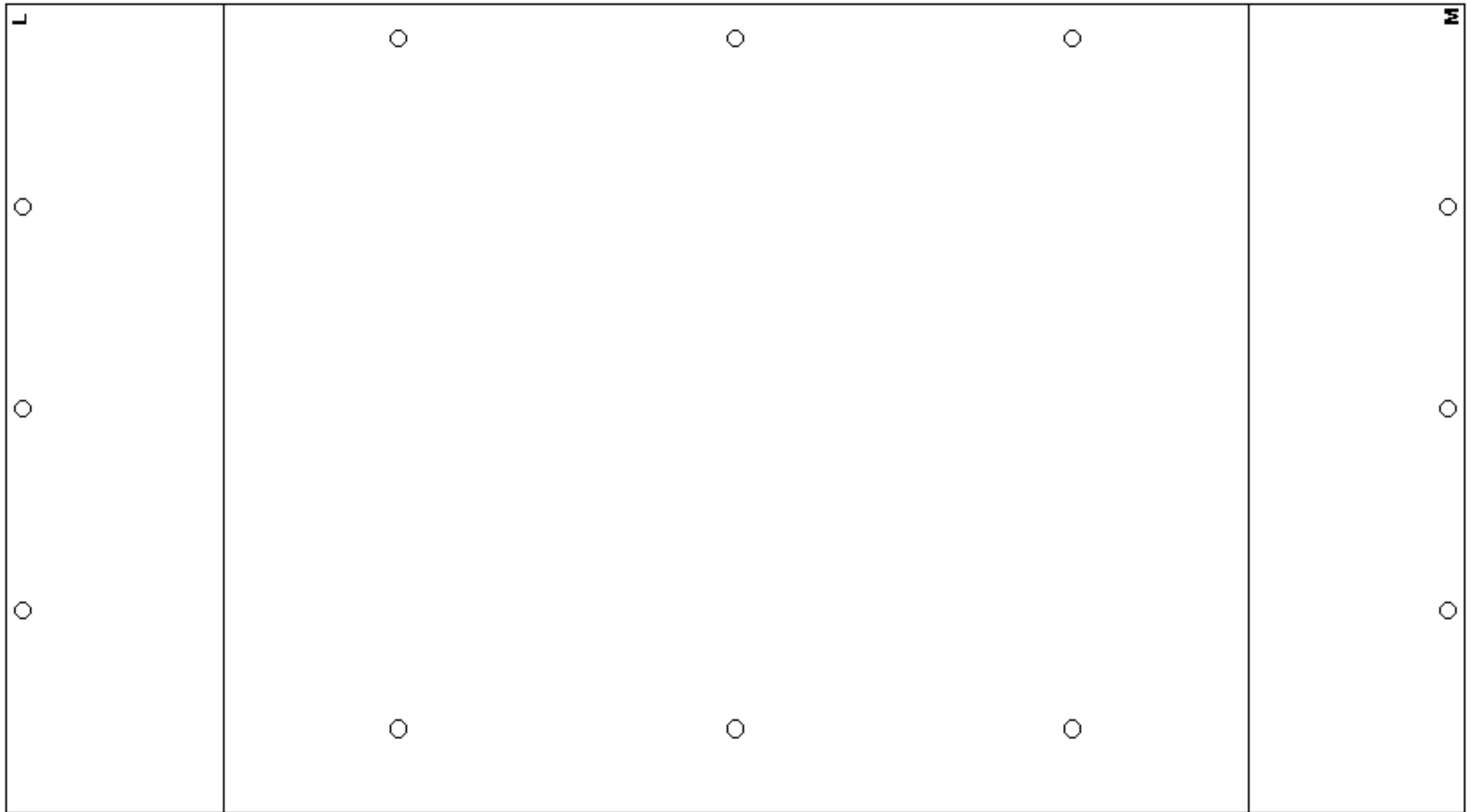

**Cutout size: 8.66" x 4.80"**

**CHASSIS COVER**  
Printer Prototype

Scale: 1:1

Drawn by: OWJ

Approved by:

***RST Engineering***

Drawing #

Date: 17 Dec 96

Rev: A

Jim Weir

13249 Grass Valley Ave Grass Valley CA 95945  
916/272-2203 (voice & fax) rst-engr@oro.net

564-0613